

BROKK 120D^{II}



The Mark of Diesel-driven Excellence

The world's smallest diesel-driven demolition machine, the **BROKK 120D^{II}** offers flexibility without compromise. Its small size enables it to enter through any standard door opening and makes it easy to maneuver in tight spaces. Running cordless, it can operate for a minimum of eight hours without refueling. The Mark^I version comes with the full Brokk SmartConcept – SmartPower™, SmartDesign™ and SmartRemote™. And it keeps the outstanding power and performance that make Brokk machines unique.

- World's smallest diesel-driven demolition machine
- Ideal for sites that lack reliable power supply
- Rugged and reliable Brokk SmartPower™
- Brokk SmartDesign™ and SmartRemote™
- Tool compatibility with Brokk 110
- Fast tracking speed for high mobility

RANGE

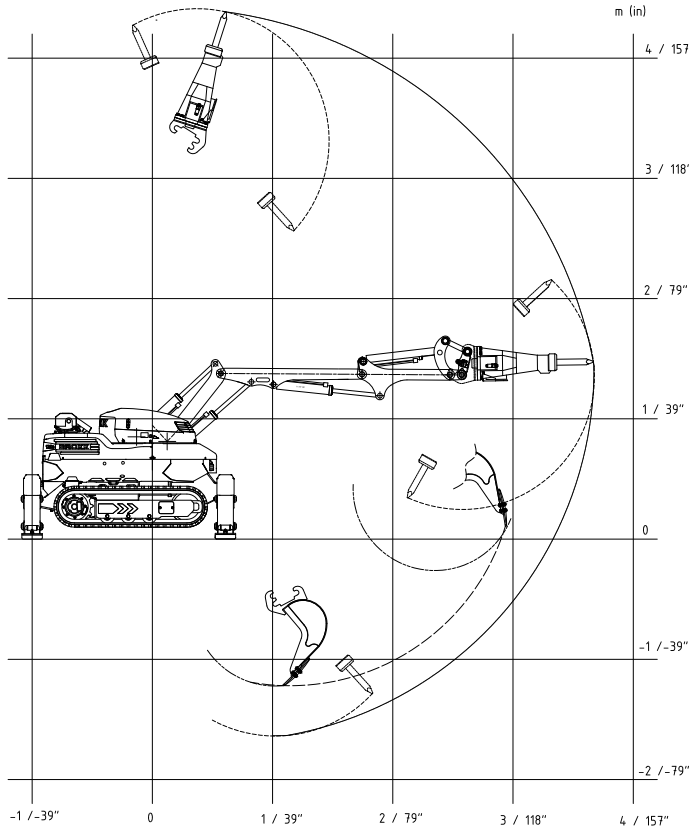

SIZE

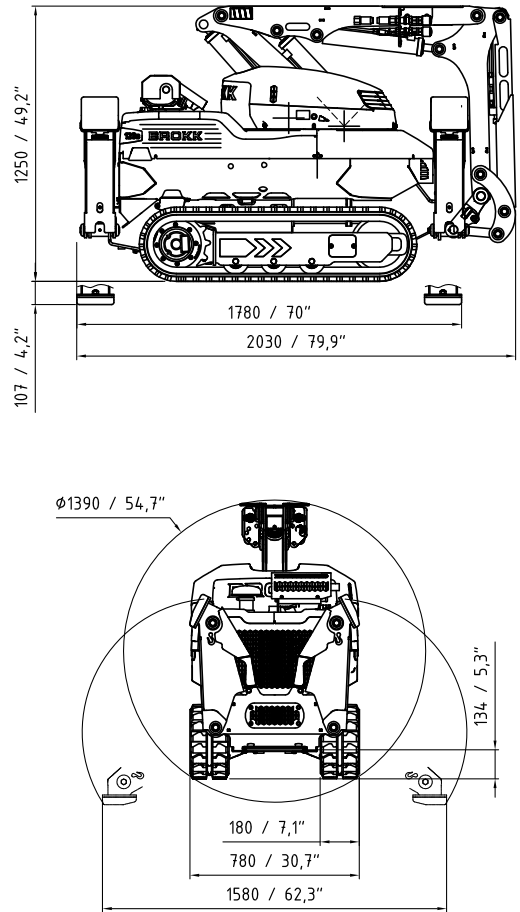

TECHNICAL DATA

Hydraulic breaker in illustrations BHB 155
Load and stability diagram available on request

Performance

Slewing speed 10 sec/360°
Transport speed, max. 3 km/h; 1.9 mph
Climbing inclination, max. 30°

Hydraulic system

Hydraulic system capacity 45 l; 12 US gal
Pump type Gear pump with fixed displacement
System pressure* 18 MPa; 2 610 psi
Pump flow 50 l/min; 13 US gal/min

Diesel performance

Type Three-cylinder, water-cooled, 4-stroke engine
Engine 18,5 kW; 24.8 hp diesel EPA Tier 4
Fuel tank capacity 30 l; 7.9 US gal
Engine oil volume 5,1 l; 1.35 US gal
Coolant volume 4,4 l; 1.2 US gal
Freezing point -40°C; -40°F

Control system

Control type SmartRemote, portable control
Signal code Digital
Transfer Professional radio/Cable
Range, radio Up to 300 m

Weight

Machine weight** 1 230 kg; 2 712 lbs
Recommended attachment weight 160 kg; 353 lbs

Noise level

Sound power level L_{WA} *** 101 dB(A)

*Hydraulic pressure can be increased depending on the attachment
**Excluding options and attachment
***Measured according to directive 2000/14/EC, excl. attachment

OPTIONS

Arm System

Impact and heat protection for cylinder C2 and C3

Undercarriage

Rubber caterpillar tracks
Steel caterpillar tracks

Heat resistance

Heat resistant hoses for hydraulic breaker
Forced draft cooling of machine
Forced draft cooling of breaker
Steel pads for machines placed on hot ground

Other options

Air flushing through breaker to protect from dust
Water spray through breaker to bind dust
Extra hydraulic function
Drainage hose
CAN cable connection
Lifting eyes (regular lifting points are standard)

TOOLS

